

DYNA-HANGER® II SUSPENSION SYSTEM

Designed for Safe, High-Load, Mid-Span Cable Connections

PRODUCT DESCRIPTION

DYNA-HANGER II Suspension System (DYNA II®) allows high-strength cable connection with many attachment possibilities. With reusable hardware, retermination kit availability and multiple options and accessories, the DYNA II offers tremendous value.

APPLICATIONS

- Towed cable arrays
- Attachment of lines or paravanes to tow underwater cables in flank positions aft of a vessel
- Buoy attachment to restrain cable torque and rotation
- Surface and subsurface float mid-span cable attachment points

FEATURES AND BENEFITS

- Design allows for ease of installation with faster cable deployments and retrievals
- Installation can be performed quickly anywhere along the cable by wrapping helical rods on the cable lead-in and installing the split housing and collar assembly with secure quick release pins
- Designed to handle in-line loads equal to safe working load of the cable and side loads of 40 tonnes (metric)
- Provides tailored bending protection and eliminates localized clamping forces through the use of helical rod layers
- Re-usable hardware and re-termination kit availability offers significant cost-savings
- Several configuration kits and accessories are available to match your application
 - Weak link (break away feature)
 - Sheave kit
 - Multiple pad-eye attachment option
 - Rotating sheave kit



TYPICAL CONFIGURATION OF THE DYNA II®

- 1 - Sheave Pin or Optional Weak Link
- 2 - Sheave
- 3 - Hand Nut & Q-R Pin
- 4 - Rotating Sheave Mount
- 5 - Housing
- 6 - Suspension Arm Pin Assembly
- 7 - Collar Assembly

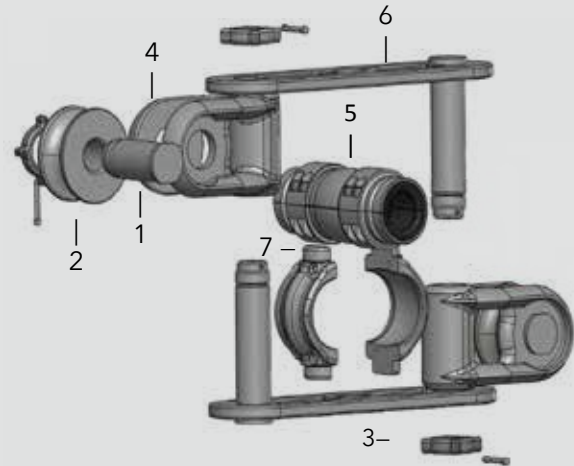

MODEL	APPROX. WEIGHT (W/O RODS)	DESIGNED FOR SPUR LINE OR SPREADER ROPES	OVERALL DIMENSIONS (L x W x H)
DYNA II	49 kg (108 lbs)	N/A	55.9 cm x 15.2 cm x 30.5 cm (22" x 6" x 12")
DYNA II w/ Sheaves	59 kg (130 lbs)	≤ 52 mm	55.9 cm x 15.2 cm x 30.5 cm (22" x 6" x 12")
DYNA II w/ Rotating Arms & Sheaves	82 kg (180 lbs)	≤ 52 mm	86.4 cm x 15.2 cm x 30.5 cm (34" x 6" x 12")

All specifications are approximate and subject to change

DYNA II® OPTIONS AND ACCESSORIES

- **SHEAVES:** available for spur lines or spreader ropes up to 52mm
- **ROTATING SHEAVE MOUNT:** adds an extra degree of freedom; allows spreader ropes to self-align for reliability during turns
- **WEAK LINK:** used with rotating sheave arms, designed to release at a specified load, ie (25T - 40T) to protect equipment from accidental overloads
- **PAD-EYE:** pad-eye collar option allows for 2, 3 or 4 pad-eye attachment points

TECHNICAL SUPPORT

If you have questions or concerns about any PMI product, please contact our engineering staff directly.
 PMI Industries, Inc. | 990 Resource Drive | Cleveland, Ohio 44131 U.S.A. | sales@pmiind.com

